

Meeting Agenda
Farmington High School Building Committee Meeting
FHS Library/ZOOM Webinar
Wednesday, July 6, 2022
5:00 P.M.

PLEASE NOTE THIS WILL BE AN ONLINE MEETING

Please click the link below to access the webinar:

<https://us02web.zoom.us/j/85071624477>

Telephone Call in Information:

Dial: +1 312 626 6799

Webinar ID: 850 7162 4477

- A. Call to Order.
- B. Pledge of Allegiance.
- C. Public Comment.
- D. Minutes.
 - 1) To approve the attached June 8, 2022 minutes.
 - 2) To approve the attached June 15, 2022 minutes.
- E. Correspondence Received 6/14/2022 – 6/30/2022
- F. Reports.
 - 1) Chair Report.
 - 2) Town Council Liaison Report.
 - 3) Board of Education Liaison Report.
 - 4) 1928 Building Committee Liaison Report.
 - 5) Owner’s Representative Report.
 - 6) Architect Report.
 - 7) Construction Manager Report.
 - 8) Communications Subcommittee Report.
 - 9) Professional Partnership Subcommittee Report.
 - 10) Financial Report.
- G. New Business.
 - 1) To approve the attached invoice from Tall Timbers Marketing in the amount of \$7,500.00.

- 2) To accept the updated cost estimate and approve the updated VE list and alternate list as presented.

H. Adjournment.

cc: Committee Members
Maureen Frink, Town Clerk
Interested Parties

MOTION:

Agenda Item D-1

To approve the attached June 8, 2022 minutes.

/Attachment

Meeting Minutes
Farmington High School Building Committee Meeting
FHS Library/ZOOM Webinar
Wednesday, June 8, 2022
5:00 P.M.

Attendees:

Meg Guerrera, Chair
Sarah Healey
Johnny Carrier
Michael Smith (via ZOOM)
Beth Kintner (via ZOOM)
Kathy Greider, Superintendent of Schools
Alicia Bowman, Asst. Superintendent of Finance & Operations (via ZOOM)
Sam Kilpatrick, Director of School Facilities
Scott Hurwitz, FHS Principal (via ZOOM)
Kat Krajewski, Assistant Town Manager
Devon Aldave, Clerk of the Committee
Chris Cykley, Construction Solutions Group
Mark Garilli, Construction Solutions Group
Mike Small, Construction Solutions Group
Ryszard Szczypek, TSKP Studio
Lorel Purcell, O&G Industries
Mark Jeffko, O&G Industries
Nelson Reis, O&G Industries

A. Call to Order.

The meeting was called to order at 5:03 P.M.

B. Pledge of Allegiance.

The committee members recited the Pledge of Allegiance.

C. Public Comment.

None.

D. Minutes.

1) To approve the attached May 25, 2022 minutes.

Upon a motion made and seconded (Healey/Smith) it was unanimously VOTED: to approve the May 25, 2022 minutes.

E. Correspondence Received 5/24/2022 – 6/6/2022

1) Henry P

Meg Guerrera reviewed the correspondence received.

F. Reports.

1) Chair Report.

No report.

2) Town Council Liaison Report.

No report.

3) Board of Education Liaison Report.

No report.

4) 1928 Building Committee Liaison Report.

Chris Fagan was not able to attend the meeting, but he provided a report to Meg Guerrera. Meg stated that the 1928 Building Committee met to discuss their aggressive timeline which includes a target referendum date of May 2023. The 1928 Building Committee also discussed their communications vision, setting up meetings with stakeholders, and creating an RFQ for architectural design.

5) Owner's Representative Report.

Mark Garilli reported that contracts for Structural Threshold Peer Review and for Third Party Code Review Services have been signed. Mark stated that O&G is working on a cost estimate based on the pricing set that TSKP Studio provided, and that the estimate is due next week. A cost estimate reconciliation meeting is tentatively scheduled for June 22nd. Mark will meet with Library staff this Friday to discuss the early enabling site work that will be done.

6) Architect Report.

Ryszard Szczypek reported that TSKP Studio has answered several questions from O&G regarding the pricing set to assist in the cost estimating process. Ryszard reported that a meeting was held on June 6th with Physical Education and Athletics staff. A school safety/security meeting was held this morning, as well as a hardware meeting. A future meeting will be scheduled to discuss signage. Ryszard also reported that a meeting was held to discuss CT High Performance Building Standards.

7) Construction Manager Report.

Loel Purcell reported that there are no significant updates to the pre-construction schedule. O&G discussed the Phase I Bid- Early Enabling and the Phase I Guaranteed Maximum Price (GMP) with the work group. O&G continues to work on their cost estimate based on the pricing set submitted by TSKP Studio.

8) Communications Subcommittee Report.

Meg Guerrera reported that a Community Presentation was held on June 2nd, at the Farmington Police Department. Meg reported that there was a small number of attendees, roughly 5 in person and 10 on ZOOM. She stated that the presentation went well, and the attendees asked great questions and provided useful feedback. Devon Aldave reported that there were nearly 150 views online (via Facebook and YouTube) at the time of this meeting. Some of the

feedback included neighborhood engagement. Mark Jeffko stated that O&G can work to create a one-pager to deliver to the abutting neighborhood regarding the early enabling package.

9) Professional Partnership Subcommittee Report.

No report.

10) Financial Report.

No report.

G. New Business.

1) To approve the following invoice package:

Name	Amount	Description
Construction Solutions Group	\$22,597.00	Professional Services May 2022 (FHS)
Construction Solutions Group	\$1,030.00	Professional Services May 2022 (900 Wing)
TSKP Studio	\$292,800.00	Professional Services May 2022 (FHS)
TSKP Studio	\$12,200.00	Professional Services May 2022 (900 Wing)
Innovative Engineering Services	\$3,040.00	Professional Services (FHS)

Upon a motion made and seconded (Healey/Smith) it was unanimously VOTED: to approve the invoice package.

2) To approve the scope award letter to release Gerber Construction, Inc. for bid package 1.01-Sitework Enabling Phase in the amount of \$1,815,000.00.

Mark Garilli and Lorel Purcell reviewed the Guaranteed Maximum Price documents and the scope award letter to release Gerber Construction, Inc. Lorel explained that this process for Phase I – Early Enabling is the same process that the committee will go through for Phase II. Mark Garilli presented a Phase I Enabling Summary, which is recorded with these minutes as Attachment A.

Committee members asked questions regarding the following topics:

- Contract Allowances
- Contingency
- Builder’s Risk Policy

- Confidence in Cost Estimating
- COVID language in the Construction Manager Contract

After reviewing the Phase I cost estimate from O&G Industries, Town staff will schedule a meeting with O&G prior to June 15th, to address discrepancies that were identified in O&G's cost estimate. This meeting will help clarify questions that were brought up by the Town staff.

Upon a motion made and seconded (Carrier/Healey) it was unanimously VOTED: to table this agenda item until the June 15, 2022 meeting.

3) To accept a Guaranteed Maximum Price of \$2,105,054 for Phase I Enabling.

Upon a motion made and seconded (Carrier/Healey) it was unanimously VOTED: to table this agenda item until the June 15, 2022 meeting.

4) To cancel the June 15, 2022, FHS Building Committee meeting.

No action was taken.

H. Adjournment.

Upon a motion made and seconded (Carrier/Healey) it was unanimously VOTED: to adjourn at 7:32 P.M.

Respectfully Submitted,

Devon Aldave
Clerk of the Committee



DRAFT

FARMINGTON HIGH SCHOOL BUILDING PROJECT

**10 MONTIETH DRIVE
FARMINGTON, CT 06032**

DESIGN DEVELOPMENT ESTIMATE

**Reconciliation through
April 14, 2022**

Revised for Phase-1 Enabling Package Bid Results - June 6, 2022

ARCHITECT

**TSKP STUDIO
HARTFORD, CT**

DRAFT

**PREPARED BY: TRACY BRENNAN
LEAD ESTIMATOR**

**DAVID LONGO
SENIOR ESTIMATOR**

**LOREL PURCELL
PRECONSTRUCTION MANAGER**

**MARK JEFFKO
PROJECT EXECUTIVE**



FARMINGTON HIGH SCHOOL BUILDING PROJECT

FARMINGTON, CT 06032

Reconciliation Through

April 14, 2022

Revised for Phase-1 Enabling Package Bid Results - June 6, 2022

DESIGN DEVELOPMENT ESTIMATE

PROJECT COST SUMMARY

DRAFT

DESCRIPTION	QTY	U/M	UNIT COST	FARMINGTON HIGH SCHOOL	FARMINGTON PUBLIC SCHOOLS CENTRAL OFFICE	TOTAL
CONSTRUCTION COSTS						
1. SITEWORK	23.2	AC	-	----		----
A. PH-1 ENABLING PACKAGE				1,833,000		1,833,000
B. HIGH SCHOOL				12,122,142		12,122,142
C. FPS - CENTRAL OFFICE				----	265,822	265,822
D. GRANITE CURBING				411,222		411,222
E. POST TENSION CONCRETE SLABS AT TENNIS COURTS				605,796		605,796
F. THICKENED ASPHALT PAVEMENT				167,284		167,284
G. UNDERGROUND UTILITIES				127,520		127,520
H. RAISE BASEBALL/TENNIS AREA				(221,513)		(221,513)
I. SCOPE FROM PH-2 SITE TO PH-1 ENABLING PKG.				(609,044)		(609,044)
2. ABATE/DEMO EXISTING BUILDINGS						
A. BUILDING DEMOLITION (EXCLUDES 1928 BUILDING)				----		----
I. HAZMAT ABATEMENT - ATC REPORT	166,353	SF	6.53	1,087,029	----	1,087,029
II. BLDG. DEMOLITION - ALLOWANCE	166,353	SF	7.00	1,164,471	----	1,164,471
B. SELECT DEMOLITION - ALLOWANCE				----		----
I. HAZMAT ABATEMENT - ATC REPORT	19,690	SF	-	NONE	NONE	----
II. SELECT DEMO	19,690	SF	8.13	27,438	132,662	160,101
3. BUILDING CONSTRUCTION						
A. NEW HIGH SCHOOL	268,200	SF		----	----	----
B. RENO HIGH SCHOOL FIELD HOUSE	248,280	SF	324.27	80,510,487	----	80,510,487
C. RENO FPS - CENTRAL OFFICE	7,090	SF	189.36	1,342,568	----	1,342,568
	12,830	SF	199.69		2,561,985	2,561,985
4. VM / SCOPE REVISIONS						
A. ACCEPTED VM ITEMS - 05/05/2022				(4,097,693)	(32,841)	(4,130,535)
B. CREDIT PH-1 ENABLING TEMP TREE-LINE FENCE				(70,000)	----	(70,000)
SUBTOTAL:				94,400,707	2,927,628	97,328,335
REIMBURSABLES						
5. CT STATE SALES TAX (EXEMPT)						
6. BUILDING PERMIT FEE (ASSUME WAIVED)						----
7. STATE EDUCATION FEE (BY OWNER)						----
8. CONSTRUCTION PHASE STAFFING	34.0	MO				----
A. EARLY SITE ENABLING PACKAGE	2.0	MO	76,300	152,600	----	152,600
B. HIGH SCHOOL	32.0	MO	116,161	3,717,147	----	3,717,147
C. FPS - CENTRAL OFFICE	6.0	MO	30,953	----	185,717	185,717
9. CM REIMBURSABLES	1.0	LS		190,713	10,038	200,750
SUBTOTAL:				4,060,460	195,755	4,256,214
CONTINGENCY						
1. DESIGN/ESTIMATE CONTINGENCY	3.94%			3,720,246	115,451	3,835,697
2. ESCALATION (8.0%/yr. to 08/01/2022 Bid)	3.67%			3,595,493	111,580	3,707,072
3. CMR - GMP CONTINGENCY (3.0 %)	3.00%			3,049,632	94,640	3,144,271
SUBTOTAL:				10,365,370	321,670	10,687,040
CM FEES						
1. PRE-CON PHASE	1.0	LS		227,500	22,000	249,500
2. CONSTRUCTION PHASE	1.25%			1,359,556	43,063	1,402,619
SUBTOTAL:				1,587,056	65,063	1,652,119
CM: BOND / INSURANCE						
1. PERFORMANCE & PAYMENT BOND	0.617%			680,869	21,657	702,526
2. INSURANCE GL / PL	0.850%			943,775	30,020	973,795
SUBTOTAL:				1,624,644	51,677	1,676,322
TOTAL ESTIMATED CONSTRUCTION COSTS (by Project)				\$ 112,038,237	\$ 3,561,793	115,600,030
UNIT PRICES FOR REFERENCE:				\$ 451.26	\$ 277.61	442.73
TOTAL CONSTRUCTION BUDGET				\$ 112,582,791	\$ 3,017,239	115,600,030
VARIANCE: + OVER / - (UNDER)				\$ (544,554)	\$ 544,554	0.00

Item	Delta
PH 1 Early Enabling	\$ 1,048,405.00
Scope from PH 2 Site to PH 1 Enabling	\$ (609,044.00)
Credit PH 1 Enabling Temp Tree Line Fence	\$ (70,000.00)
Budget Variance over/under	\$ (361,122.00)
Design and Estimating Contingency Adjustment	\$ (8,239.00)
	\$ -



FARMINGTON HIGH SCHOOL
 Farmington, CT

PHASE 1 OF 4
 EARLY SITE ENABLING

DRAWING TITLE
 EARLY SITE ENABLING -
 SITEWORK PLAN

STATE PROJ. NO. 052-0076N
 PROJ. NO. 190701
 SCALE 1" = 30'-0"
 DATE 23 MARCH 2022
 DRAWN BY JPE
 APPROVED BY MAC

ISSUE DATES		
NO.	DATE	PURPOSE

L6.11

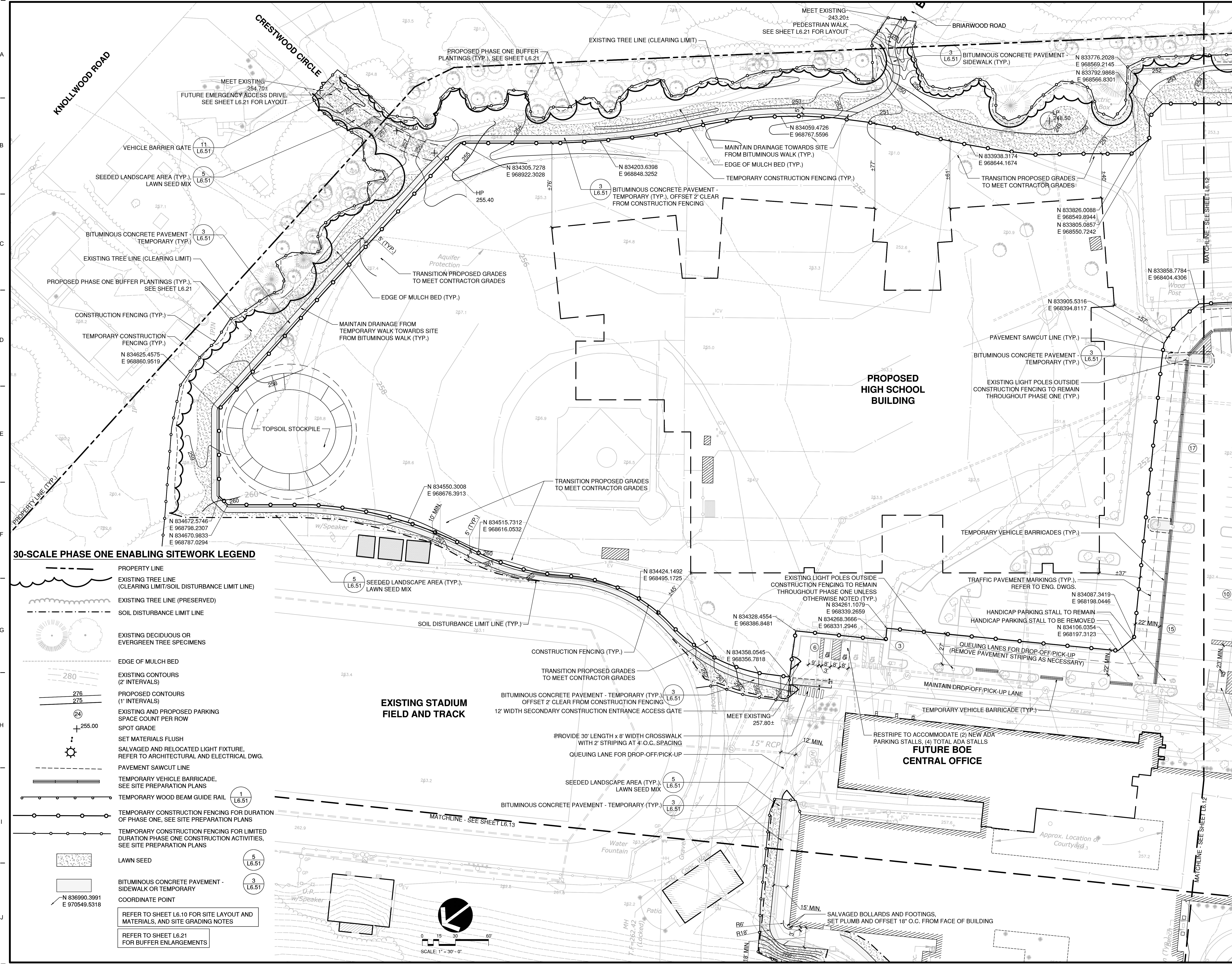

30-SCALE PHASE ONE ENABLING SITEWORK LEGEND

- PROPERTY LINE
 - EXISTING TREE LINE (CLEARING LIMIT/SOIL DISTURBANCE LIMIT LINE)
 - EXISTING TREE LINE (PRESERVED)
 - SOIL DISTURBANCE LIMIT LINE
 - EXISTING DECIDUOUS OR EVERGREEN TREE SPECIMENS
 - EDGE OF MULCH BED
 - EXISTING CONTOURS (2' INTERVALS)
 - PROPOSED CONTOURS (1' INTERVALS)
 - EXISTING AND PROPOSED PARKING SPACE COUNT PER ROW
 - SPOT GRADE
 - SET MATERIALS FLUSH
 - SALVAGED AND RELOCATED LIGHT FIXTURE, REFER TO ARCHITECTURAL AND ELECTRICAL DWG.
 - PAVEMENT SAWCUT LINE
 - TEMPORARY VEHICLE BARRICADE, SEE SITE PREPARATION PLANS
 - TEMPORARY WOOD BEAM GUIDE RAIL (1 L6.51)
 - TEMPORARY CONSTRUCTION FENCING FOR DURATION OF PHASE ONE, SEE SITE PREPARATION PLANS
 - TEMPORARY CONSTRUCTION FENCING FOR LIMITED DURATION PHASE ONE CONSTRUCTION ACTIVITIES, SEE SITE PREPARATION PLANS
 - LAWN SEED (5 L6.51)
 - BITUMINOUS CONCRETE PAVEMENT - SIDEWALK OR TEMPORARY (3 L6.51)
 - COORDINATE POINT
- REFER TO SHEET L6.10 FOR SITE LAYOUT AND MATERIALS, AND SITE GRADING NOTES
 REFER TO SHEET L6.21 FOR BUFFER ENLARGEMENTS

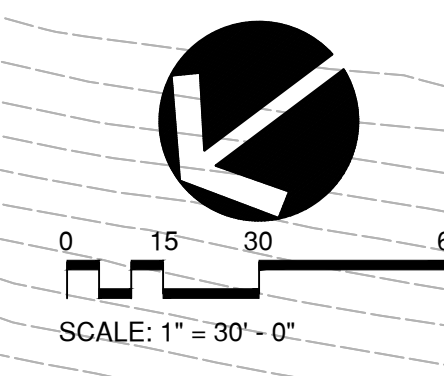

MOTION:

Agenda Item D-2

To approve the attached June 15, 2022 minutes.

/Attachment

**Meeting Agenda
Farmington High School Building Committee Meeting
ZOOM Webinar
Wednesday, June 15, 2022
5:00 P.M.**

Attendees:

Meg Guerrera, Chair
Johnny Carrier
Suraj Kurtakoti
Wendy Ku
Sarah Healey
Chris Fagan
Michael Smith
Beth Kintner
Kathy Greider, Superintendent of Schools
Sam Kilpatrick, Director of School Facilities
Scott Hurwitz, FHS Principal
Kat Krajewski, Assistant Town Manager
Devon Aldave, Clerk of the Committee
Mark Garilli, Construction Solutions Group
Chris Cykley, Construction Solutions Group
Mike Small, Construction Solutions Group
Nelson Reis, O&G Industries
Lorel Purcell, O&G Industries
Mark Jeffko, O&G Industries

A. Call to Order.

The meeting was called to order at 5:04 P.M.

B. Pledge of Allegiance.

The committee members recited the Pledge of Allegiance.

C. Public Comment.

Jay Tulin, 39 Timberline Drive, stated that he would like to see more interaction between TSKP Studio and the Institute for Human Centered Design regarding universal design.

D. Correspondence Received 6/7/2022 – 6/13/2022

1) Jay Tulin

2) Stephen Kay

Prior to reviewing the correspondences received, Meg Guerrera congratulated Dr. Alicia Bowman for recently obtaining her Doctorate degree. Meg also congratulated the FHS Class of 2022.

E. New Business.

1) To approve the following invoice package:

Name	Amount	Description
O&G Industries	\$17,500.00	Professional Services May 2022 (FHS)
O&G Industries	\$1,692.31	Professional Services May 2022 (900 Wing)

Upon a motion made and seconded (Fagan/Ku) it was unanimously VOTED: to approve the invoice package.

2) To approve the scope award letter to release Gerber Construction, Inc. for bid package 1.01-Sitework Enabling Phase in the amount of \$1,815,000.00.

Upon a motion made and seconded (Fagan/Ku) it was unanimously VOTED: to approve the scope award letter to release Gerber Construction, Inc. for bid package 1.01-Sitework Enabling Phase in the amount of \$1,815,000.00.

3) To accept a Guaranteed Maximum Price of \$2,105,054 for Phase I Enabling.

Mark Garilli explained that the professional partnership team held a meeting with Town Staff where they reviewed the cost estimate.

Upon a motion made and seconded (Fagan/Ku) it was unanimously VOTED: to accept a Guaranteed Maximum Price of \$2,105,054 for Phase I Enabling.

4) To cancel the June 22, 2022, FHS Building Committee Meeting.

Before taking action on this agenda item, Meg Guerrera explained that the Design Working Group met prior to this meeting. At the working group meeting, the group revisited the Ed Specs, which included language regarding an operable partition in the gym. TSKP Studio will begin working on this design.

Upon a motion made and seconded (Fagan/Ku) it was unanimously VOTED: to cancel the June 22, 2022 FHS Building Committee meeting.

F. Adjournment.

Upon a motion made and seconded (Fagan/Healey) it was unanimously VOTED: to adjourn at 5:22 P.M.

Respectfully Submitted,
Devon Aldave
Clerk of the Committee

MOTION:

Agenda Item G-1

To approve the attached invoice from Tall Timbers Marketing in the amount of \$7,500.00.

/Attachment



Invoice #

7_1_22

Date: 7/1/2022

Tall Timbers Marketing LLC

P.O. Box 357
Glastonbury, CT 06033

Sold to:

Town of Farmington/FHS
Building Committee
Kathryn Krajewski
Assistant Town Manager
1 Monteith Drive
Farmington, CT 06032

Customer ID: 1104-1

Customer PO	Payment Terms	Due Date
3395	Net 10 Days	7/1/2022

Description	Amount
<p>PHASE 2—Community Communication Strategy and Tactics July 2022 to June 2023</p> <p>Tasks (Based upon the phases and milestones of the project)</p> <ul style="list-style-type: none"> • Create/distribute newsletter every 6 months • Prep for building committee In person and/or Zoom meetings • Review and recommend changes to website • Social media monitoring and messaging • Prep communication sub-committee • Create a yearly video highlighting past year progress • Prep for media/articles for local and regional outlets <p>Billing for the newsletter will be based upon the following specs and will be sent when delivered to PO:</p> <ul style="list-style-type: none"> • Print 11,450 copies: 4 color, 4 or 6 pages, • Mailing List for all Farmington households • Fold and tab, address presort for post office, delivery <p>Postage prepaid at Farmington Post Office by the Town of Farmington</p>	<p>\$7500.00</p>

00

Please make payable to: Tall Timbers Marketing LLC

MOTION:

Agenda Item G-2

To accept the updated cost estimate and approve the updated VE list and alternate list as presented.

NOTE: The VE list and alternate list were developed by the professional partners and approved by the working group.

/Attachment

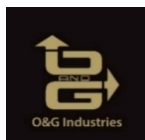

FARMINGTON HIGH SCHOOL BUILDING PROJECT

FARMINGTON, CT 06032

June 15, 2022

RECONCILED:

June 30, 2022

CONSTRUCTION DOCUMENTS - PRICING SET
PROJECT COST SUMMARY

DESCRIPTION	QTY	U/M	UNIT COST	FARMINGTON HIGH SCHOOL	FARMINGTON PUBLIC SCHOOLS CENTRAL OFFICE	TOTAL
CONSTRUCTION COSTS						
1. SITWORK	23.2	AC				
A. EARLY ENABLING PACKAGE				1,833,000	----	1,833,000
i. PHASE ONE VE CREDITS				(165,265)	----	(165,265)
B. HIGH SCHOOL SITE				11,208,049	----	11,208,049
C. FPS - CENTRAL OFFICE SITE				----	210,624	210,624
2. ABATE/DEMO EXISTING BUILDINGS						
A. BUILDING DEMOLITION (EXCLUDES 1928 BUILDING)						
I. HAZMAT ABATEMENT - ATC REPORT	166,353	SF	6.53	1,087,029	----	1,087,029
II. BLDG. DEMOLITION - ALLOWANCE	166,353	SF	7.00	1,164,471	----	1,164,471
B. SELECT DEMOLITION - ALLOWANCE				----		----
I. HAZMAT ABATEMENT - ATC REPORT	19,690	SF		- none -	- none -	----
II. SELECT DEMO	19,690	SF	8.16	27,935	132,662	160,597
3. BUILDING CONSTRUCTION	268,520	SF				
A. NEW HIGH SCHOOL	248,550	SF	337.71	83,938,632	----	83,938,632
B. RENO HIGH SCHOOL FIELD HOUSE	7,090	SF	192.75	1,366,573	----	1,366,573
C. RENO FPS - CENTRAL OFFICE	12,880	SF	214.03		2,756,673	2,756,673
4. ACCEPTED VM ITEMS - TBD				(2,070,517)	----	- tbd -
SUBTOTAL:				98,389,907	3,099,959	103,560,383
REIMBURSABLES						
5. CT STATE SALES TAX (EXEMPT)				----	----	----
6. BUILDING PERMIT FEE (ASSUME WAIVED)				----	----	----
7. STATE EDUCATION FEE (BY OWNER)				----	----	----
8. CONSTRUCTION PHASE STAFFING	34.0	MO				
A. EARLY SITE ENABLING PACKAGE	2.0	MO	76,300	152,600	----	152,600
B. HIGH SCHOOL	32.0	MO	116,161	3,717,147	----	3,717,147
C. FPS - CENTRAL OFFICE	6.0	MO	30,953	----	185,717	185,717
9. CM REIMBURSABLES	1.0	LS		190,713	10,038	200,750
SUBTOTAL:				4,060,460	195,755	4,256,214
CONTINGENCY						
1. DESIGN/ESTIMATE CONTINGENCY	1.00%			983,899	31,000	1,014,899
2. ESCALATION (8.0%/yr. to Bid Date)	1.82%			1,809,769	57,020	1,866,790
3. CMR - GMP CONTINGENCY (3.0 %)	3.00%			3,035,507	95,639	3,131,147
SUBTOTAL:				5,829,176	183,659	6,012,835
CM FEES						
1. PRE-CON PHASE	1.0	LS		227,500	22,000	249,500
2. CONSTRUCTION PHASE	1.25%			1,353,494	43,492	1,396,986
SUBTOTAL:				1,580,994	65,492	1,646,486
CM: BOND / INSURANCE						
1. PERFORMANCE & PAYMENT BOND	0.617%			677,840	21,872	699,711
2. INSURANCE GL / PL	0.850%			939,576	30,317	969,893
SUBTOTAL:				1,617,416	52,189	1,669,605
TOTAL ESTIMATED CONSTRUCTION COSTS (by Project)				\$ 111,477,952	\$ 3,597,054	115,075,007
UNIT PRICES FOR REFERENCE:				\$ 448.51	\$ 279.27	440.18
TOTAL CONSTRUCTION BUDGET				\$ 112,582,791	\$ 3,017,239	115,600,030
UNIT PRICES FOR REFERENCE:				\$	234.26	442.18
VARIANCE: + OVER / - (UNDER)				\$ (1,104,839)	\$ 579,815	(525,023)

FARMINGTON HIGH SCHOOL BUILDING PROJECT

FARMINGTON, CT 06032

CONSTRUCTION DOCUMENT - PRICING SET

RECONCILED

June 30, 2022

ALTERNATES

AREA OF WORK	ALT. #	CD DOCUMENT DESCRIPTIONS	TRADE COST AMOUNT	MARKUPS	TOTAL COST
HS	1.	ADD ONE EXTERIOR HORIZONTAL SUN SHADE PER WINDOW.	\$ 320,950	\$ 27,403	\$ 348,353
HS	2.	INSTALL PORCELAIN TILE IN LIEU OF LINOLEUM TILE.	\$ 549,368	\$ 46,906	\$ 596,273
HS	3.	INSTALL WOOD CEILING IN LIEU OF ACT.	\$ 702,856	\$ 60,011	\$ 762,867
HS	4.	ADD GWB SOFFIT IN STAIRWELLS UNDER STAIRS & LANDINGS	\$ 60,165	\$ 5,137	\$ 65,302
HS	5.	INSTALL GROUND FACE CMU IN LIEU OF GYP BD PARTITION TYPE M43 WITH WALL COVERING.	\$ 161,310	\$ 13,773	\$ 175,083
HS	6.	ADD OPERABLE WINDOWS TO EXTERIOR CURTAINWALL AND STOREFRONT ASSEMBLIES.	\$ 120,000	\$ 10,246	\$ 130,246
HS	7.	CONSTRUCT A BALLFIELD IN LIEU OF A NEW GRASSY FIELD.	\$ 1,248,083	\$ 106,563	\$ 1,354,646
HS	8.	DELETE THE ABATEMENT AND DEMOLITION OF AREA G IN THE EXISTING HIGH SCHOOL PER THE DEMOLITION DRAWINGS.	\$ (895,470)	\$ (76,457)	\$ (971,926)
HS	9.	ADD OPERABLE WALL PARTITION BETWEEN GYMNASIUMS	\$ 676,093	\$ 54,087	\$ 730,181
HS	10.	ADD ELEVATOR NO. 3 IN AREA E	\$ 166,888	\$ 13,351	\$ 180,239
SUBTOTAL - ALL ALTERNATES:					\$ 3,371,264



FARMINGTON HIGH SCHOOL BUILDING PROJECT

FARMINGTON, CT 06032

CONSTRUCTION DOCUMENT - PRICING SET

RECONCILED:

June 30, 2022

VALUE MANAGEMENT LIST

ITEM #	DESCRIPTION	QTY	UM	UNIT COST	APPROX. TRADE COST	APPROX. PROJECT COST
1	DELETE 420 SF OF SKYLIGHTS	(420.0)	SF	150.00	(63,000)	(68,040)
2	CHANGE CURTAIN WALL UNDER 12' HIGH TO STOREFRONT	3,561.0	SF	(25.22)	(89,825)	(97,011)
3	DELETE ELEVATOR # 3 IN AREA E, REPLACE WITH STORAGE CLOSET	(1.0)	EA	166,888	(166,888)	(180,239)
4	DELETE ENTRY GRILLES, MOVE TO FF&E	(1,270.0)	SF	140.00	(177,800)	(192,024)
5	REDUCE LANDSCAPING - SMALLER TREE CALIPER SIZE	1.0	LS	(28,260)	(28,260.18)	(30,521)
6	DELETE WIND SCREEN AT TENNIS COURT	1.0	LS	(33,912)	(33,912.21)	(36,625)
7	DELETE "REPLACE VEHICLE GATE WITH ELECTRONIC GATE" NOTE	1.0	LS	(45,216)	(45,216.29)	(48,834)
8	REUSE PARTIAL FF&E, REDUCE FF&E/TECHNOLOGY BUDGET	1.0	LS	(452,724)	(452,724)	(500,000)
VM SUBTOTALS:					(1,057,625)	(1,153,293)
	* MOVE TENNIS COURTS TO SEPARATE BID PACKAGE	1.0	LS	(1,012,891)	(1,012,891)	(1,100,000)
SUBTOTALS (VM + TENNIS COURT):					(2,070,517)	(2,253,293)